

HED-150 Kit Detail

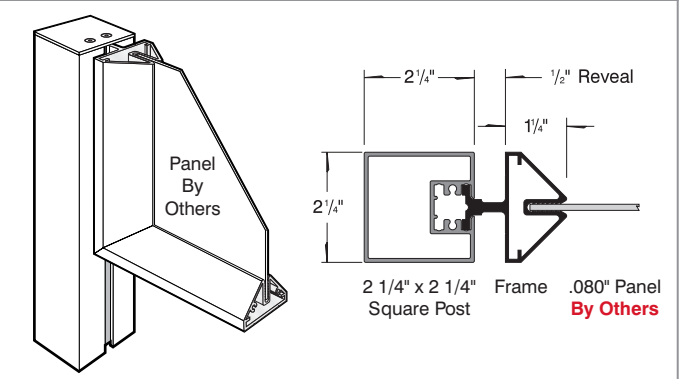

SIDE B

TOP VIEW



SIDE A

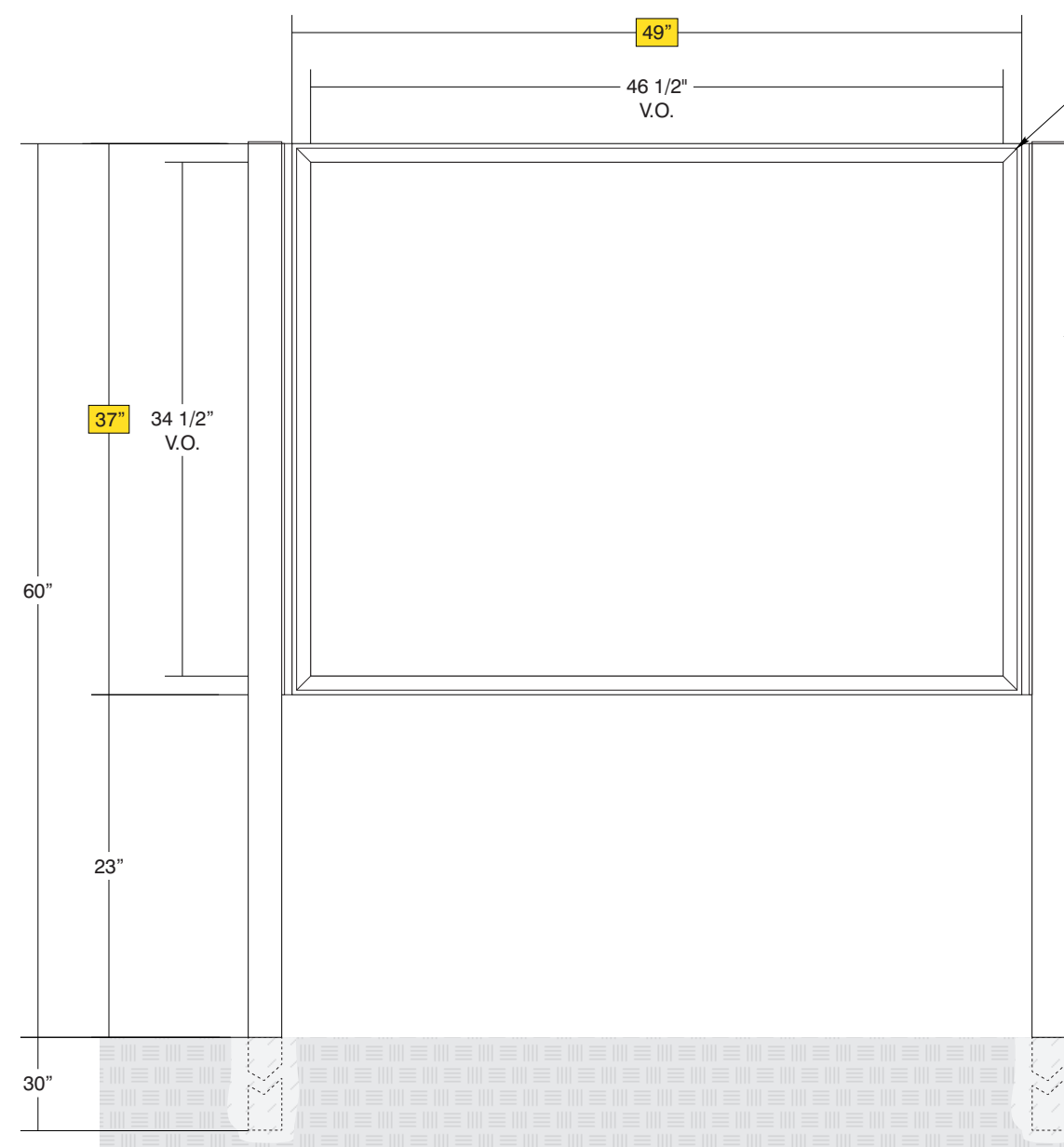

- **Sign System: HED-150 Kit**
 - (0) .080" Aluminum Panel: (H) 36" x (L) 48" **BY OTHERS**
- **Paint:**
 - Standard White - Frame, Post, Caps
- **Double Post Mount**
 - (2) Post Size: 2 1/4" x 2 1/4" x (L) 90" with Caps

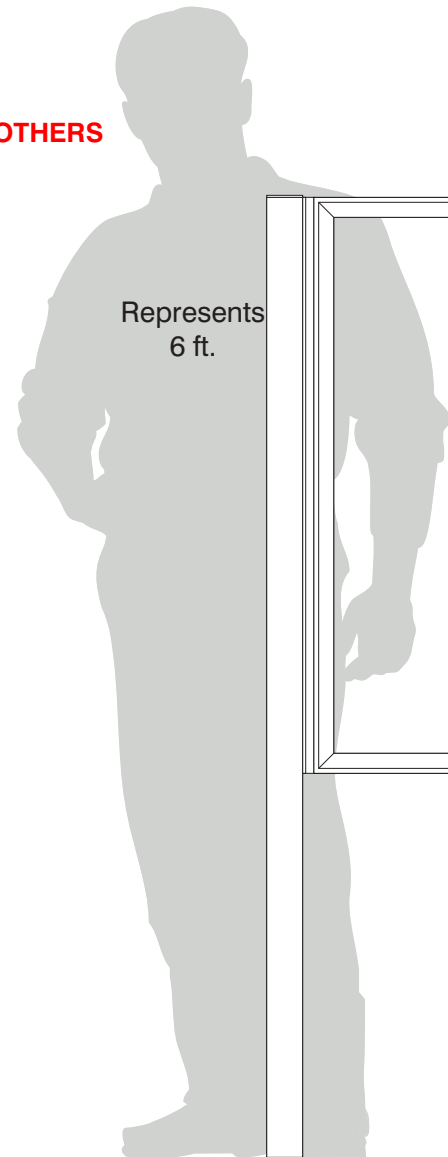

Date	DWG# HED-150_Kit	Scale:	1"=1'	Customer	Mounting	Double Post Mount		Quote #	
XX.XX.XX					SF/DF	double face		Sales Rep.	
Quantity				Location	Illuminated	NO	UL	Illustrator:	
1					Voltage	N/A	Amp	Rev. 0	
Page				System	ADA	No		Reviewed By:	
1 of 1				HED-150 (36" x 48") (No Panel) Kit Sign System	*Due to the ADA/ ANSI's wide interpretation and other factors that may exist, we cannot affirm compliance in all situations and is hereby removed from responsibility regarding these issues.				



• 6400 Howard Drive, Fairview PA 16415 • Toll Free 800.458.0591 •
 • PA 814.833.7000 • Fax 814.838.0011 •
 www.howardindustries.com

All concepts and designs represented by this drawing are the property of Howard Industries and may not be reproduced or used in any manner without written consent. ©Copyright 2020 Howard Industries.