

PERMA•BANNER

POLE MOUNT SYSTEM

Assembly and Installation Instructions

Carefully select the location of your sign to be sure that it will be readily visible to those for which it is intended. Before installing any sign, be sure that the installation does not obstruct traffic or hamper local utilities, landscape, maintenance, snow-plowing, etc...



Pole Mount

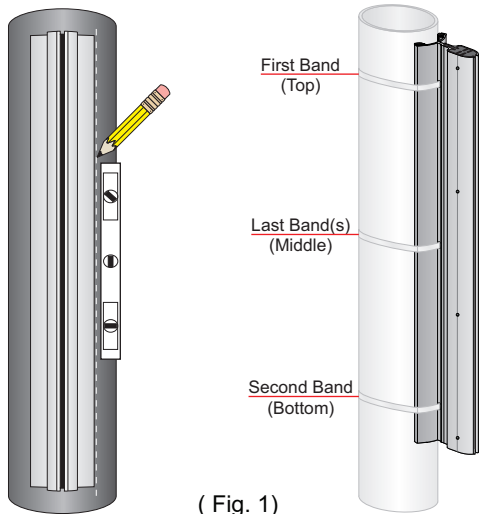

(Fig. 1)

Introduction:

Plan your installation carefully, taking note to important clearances before beginning to install Perma•Banner pole signs. Determine the direction in which the panel needs to be seen and be sure it is mounted high enough to clear vehicles on roadsides and to clear an arms length above in pedestrian walkways.

Carefully unpack the mounting frame and panel from their shipping cartons. Lay the sections onto the ground (use the shipping cartons underneath the product to prevent damage).

Note**It is recommended to level and install the Perma•Banner Extrusion Bracket first and tighten all banding to the pole prior to installing the panel.

Item 1 (Fastening Extrusion to Pole)*See Fig 1*

1. Thread the Banding through the top slot in the extrusion bracket and Fasten the top banding clamp to the pole first.
2. Make sure the extrusion is level and fasten the bottom banding clamp and tighten.
3. Thread banding clamps through each of the remaining banding slots in the banner extrusion, taking care to keep the extrusion bracket level from top to bottom and tighten each clamp. Recheck all clamps for tightness.

Item 2 (Panel Insertion)

1. Insert the 1/8" Aluminum Panel into the Extrusion Bracket with the Anti-vibration strip on the side of the panel stop (Fig. 2)
2. Insert a Knurled Barrel Nut into the top hole of the extrusion bracket opposite of the Anti-vibration strip passing through the aluminum panel. Rotate the barrel nut slightly to lock it into the grooves.
3. Tap the barrel nut into the extrusion using a rubber mallet, then insert a nyloc machine screw into the hole on the opposite side and tighten approximately half way into the barrel nut.
4. Proceed with the installation of the remaining knurled barrel nuts and nyloc screws using the same method as in step 2
5. Tighten all hardware fully.

(See Figure 3 for a top view of final assembly)

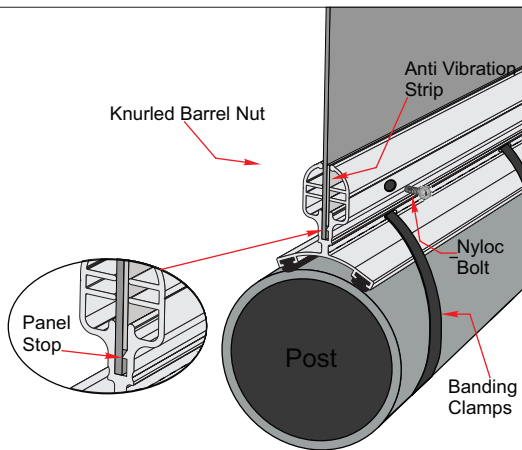

(Fig. 2)

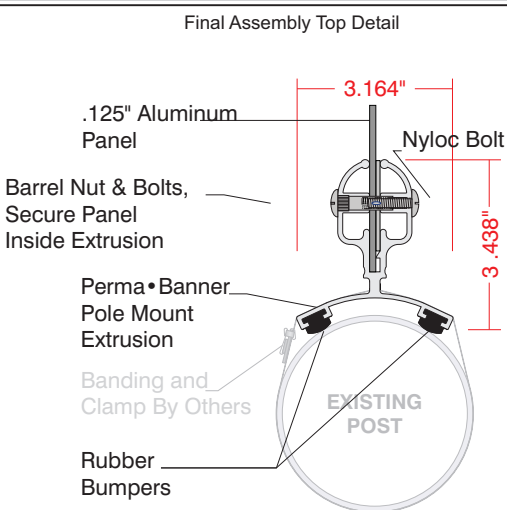

(Fig. 3)



Make-A-Clamp Banding Kit
Sold Separately





Pole Mount Continued

Item 3 (Panel Removal)

1. Loosen the Bottom Phillips Head Nyloc bolt approximately 1/4" and tap on the screw head with a rubber mallet to dislodge the knurled barrel nut. Proceed loosening of the remaining screws in the same fashion working from the bottom up.
Remove all but the top screw and nut and while holding the sign panel remove the top screw and nut and remove the panel.

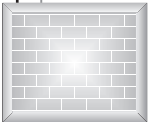
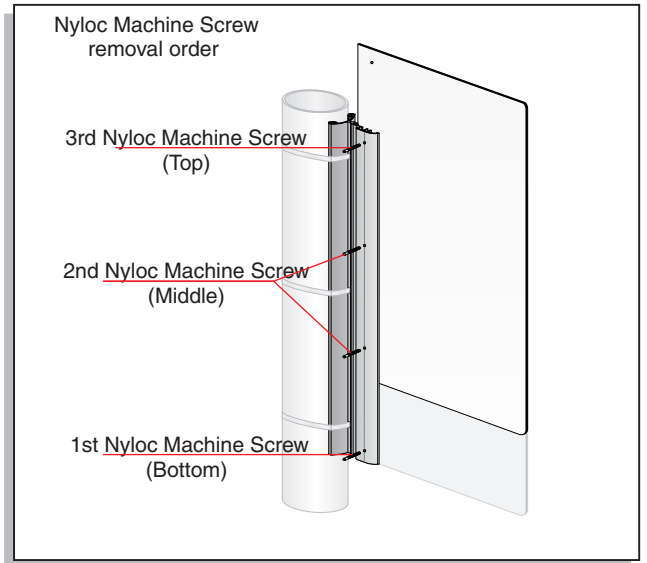

Wall Mount

Item 4 (Wall Mount)

Note** It is recommended to install the extrusion only to the wall, then attach the sign panel into the extrusion once it is fastened tight to the wall.

1. Place the sign extrusion in position, level, then locate and mark the pre-drilled holes in the brackets onto the wall. Secure all brackets to the wall using appropriate fasteners, not supplied.
2. Proceed to install the sign panel as explained in the pole mount procedure.

